

EMB25 (SL-CP25)



EMERGENCY BATTERY BACKUP FOR LED LUMINAIRES

- Input: 120-277VAC
- LED Output: 20-50VDC / 25-watts
- Battery Type: Lithium-Ion 9.6V / 6800mA
- CEC / UL Listed for field installation with conduit connections.
- Size: 11 1/4" x 2 9/16" x 1 1/2" (without conduit)



! IMPORTANT SAFEGUARDS !

WHEN USING ELECTRICAL EQUIPMENT, BASIC SAFETY PRECAUTIONS SHOULD ALWAYS BE FOLLOWED, INCLUDING THE FOLLOWING:

To prevent high voltage from being present on yellow and orange output leads prior to installation, converter connector must be open. Do not join converter connector until installation is complete and AC power is supplied to the emergency driver.

This product is for use with an LED lighting load and supplies up to 25W constant power with output voltage between 20 VDC and 50 VDC in emergency mode for a minimum of 90 minutes.

Make sure all connections are in accordance with the National Electrical Code or Canadian Electrical Code and any local regulations.

To reduce the risk of electrical shock, disconnect both normal and emergency power supplies and converter connector of the emergency driver before servicing.

This emergency driver is for factory installation and field installation.

An un-switched source of power is required (120V or 277V, 50/60Hz)

Use with grounded, UL Listed, damp location rated fixtures. Emergency driver case must be grounded.

This product is for use in ordinary locations and for permanent installation in one or more Listed emergency luminaires, for models with suffix B and C.

Do not install near gas or electric heaters. Product is not suitable for HVAC ducts, wet, or hazardous locations. Not suitable for use inside of exterior located signs.

Product is suitable for use in damp locations where the ambient temperature is 10°C minimum, 50°C maximum. Long term use over 35°C shortens life. High heat in a roof cavity or enclosure will cause product failure. Locate product in an area not heated by the sun.

Extremely low temperatures will temporarily reduce current output of battery and slow down charging.

Do not attempt to service the battery. A sealed no-maintenance battery is used. Battery is not field replaceable. Complete emergency driver unit must be replaced when worn out.

The use of accessory equipment not recommended by the manufacturer may cause an unsafe condition.

Do not use this product for other than intended use.

Installation and servicing should only be performed by qualified personnel.

Only apply to LED Driver which has an output current less than 5.0A.

Equipment should be mounted in locations and at heights where it will not be subjected to tampering by unauthorized personnel.

LED Luminaire Criteria

This product is suitable for field installation with suitable LED loads including LED luminaires, DC voltage driven LED replacements for fluorescent lamps and others. There are 4 checks to determine if your luminaire is eligible for field installation. (See below for the 4 checks.) This product will not work with "AC LED Chips" (LEDs with inaccessible on-board drivers).

1. Ensure the LED load's rated power is greater than or equal to the power output of this emergency LED driver. This is to ensure that this emergency product will not produce more power than the LED load can handle, thus ensuring that the LED load will not be damaged when the system is in the emergency mode.
2. Verify that the forward voltage of the luminaire's LED array is within the limits of this emergency LED driver. The forward voltage of the LED array is commonly designated as Vf and should be found on the luminaire markings, in the luminaire specifications, or imprinted directly on the LED arrays. If multiple LED arrays are to be driven, verify that the total forward voltage is within the limits of this product. Using a voltage meter, it may be possible to directly measure the voltage across the LED arrays when operating from the AC driver.
3. Ensure the output current of the LED driver does not exceed 5.0 Amps. This is the current into the blue wire.

Calculating Lumen Output

4. Estimate the luminaire's lumen output during battery operation using the following method:

- a. Find the efficacy of the LED load. This can be given by the luminaire manufacture or DLC test report. This number will be given in lumens per watt (lm/w).
- b. Lumens can be calculated by multiplying the output power of the emergency LED driver by the efficacy of the LED load. In many cases the actual lumen output in emergency mode will be greater than this calculation gives, however it will provide a good estimate for beginning the lighting design of the system.
- c. Using the results of this calculation and industry standard lighting design tools, calculate the anticipated illumination levels in the path of egress.

$$\text{Lumens In Emergency Mode} = \text{Lumens per Watt of Fixture} * \text{Output Power Emergency LED driver}$$
$$\underline{\hspace{2cm} \text{(Lumens)} \hspace{2cm}} = \underline{\hspace{2cm} \text{(lm/W)} \hspace{2cm}} * \underline{\hspace{2cm} 25\text{(W)} \hspace{2cm}}$$

NOTE: This product has been designed to reliably interface with a wide selection of LED loads and is electrically compatible with every simple LED array that meets criteria 1 and 2 above. However, compatibility cannot be guaranteed with all current and future LED systems. Compatibility testing of the end-use system is suggested. Please contact the factory with any questions.

NOTE: After installation, it will be necessary to measure the egress lighting illumination levels to ensure it complies with national, state, and local code requirements.

Installation



WARNING: TO PREVENT HIGH VOLTAGE FROM BEING PRESENT ON ORANGE OUTPUT LEADS PRIOR TO INSTALLATION, CONVERTER CONNECTOR MUST BE OPEN. DO NOT JOIN CONVERTER CONNECTOR UNTIL INSTALLATION IS COMPLETE AND AC POWER IS SUPPLIED TO THE EMERGENCY DRIVER.

NOTE: Make sure the necessary branch circuit wiring is available. An unswitched source of power is required. The emergency driver must be fed from the same branch circuit as the AC driver.

Installation of this emergency LED driver will vary based on the luminaire type, however, generally follow these steps:

STEP 1 INSTALLING THE EMERGENCY DRIVER

- > Disconnect AC power from the LED luminaire.
- > Mount the emergency LED driver by the mounting tabs using the supplied screws. The luminaire's installation instructions may provide guidance on the recommended mounting location.
- > The emergency driver with cable conduit suitable for remote mounting from the luminaire, emergency driver without cable conduit do not suitable for remote mounted.
If used in conjunction with an AC driver, this distance is up to half the distance the AC driver manufacturer recommends remote mounting the AC driver from the LED Load. If used without an AC driver, consult factory for remote mounting distances.
- > Mounting Height: This product meets or exceeds the NFPA minimum light requirements with all loads, down to the smallest rated lamp load, at heights up to 7.17ft (2.2m). Many factors influence emergency illumination levels, such as the lamp load selected, luminaire design, and environmental factors therefore end use verification is necessary. For field installations, when the attached luminaire is mounted at heights greater than 7.17ft (2.2m), the level of illumination must be measured in the end application to ensure the requirements of NFPA 101 and local codes are satisfied.

STEP 2 INSTALLING TEST SWITCH

Install and wire the test switch per wiring diagrams provided on these instructions.

If wired correctly, the test switch indicator light should be ON when AC power is supplied to the fixture, indicating that the emergency inverter battery is charging.

A. Test switch install on switch box, switch box install on wall or ceiling surface.

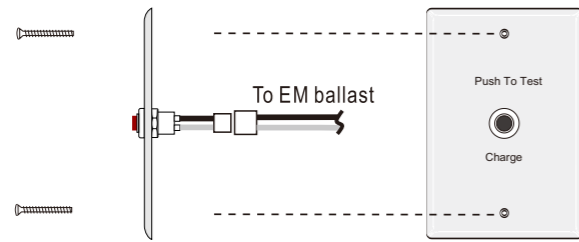

B. Install test switch on fixture surface.

Mount the supplied illuminated test switch in a location that is visible and accessible by maintenance personnel. The test switch mounts through a 0.63" hole which may need to be made in the luminaire or could come pre-punched by the luminaire supplier.

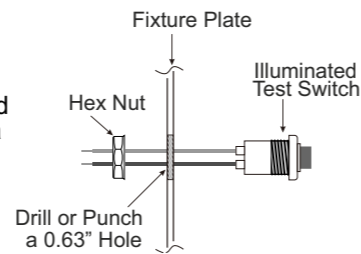

STEP 3 WIRING THE EMERGENCY BALLAST

- >According wiring diagram to connect the emergency driver to the AC driver and LED load.
- Make sure all connections are in accordance with the National Electrical Code and any local regulations.
- >After installation is complete, supply AC power to the emergency driver and join the converter connector.
- >At this point, power should be connected to both the AC driver and the emergency driver, and the Charging Indicator Light should illuminate indicating the battery is charging.
- >A short-term discharge test may be conducted after the emergency driver has been charged for one hour. Charge for 24 hours before conducting a long-term discharge test. Refer to OPERATION.
- >In a readily visible location, attach the label "CAUTION - This Unit Has More Than One Power Connection Point. To Reduce The Risk Of Electric Shock, Disconnect Both The Branch Circuit-Breakers Or Fuses And Emergency Power Supplies Before Servicing."

WIRING DIAGRAM

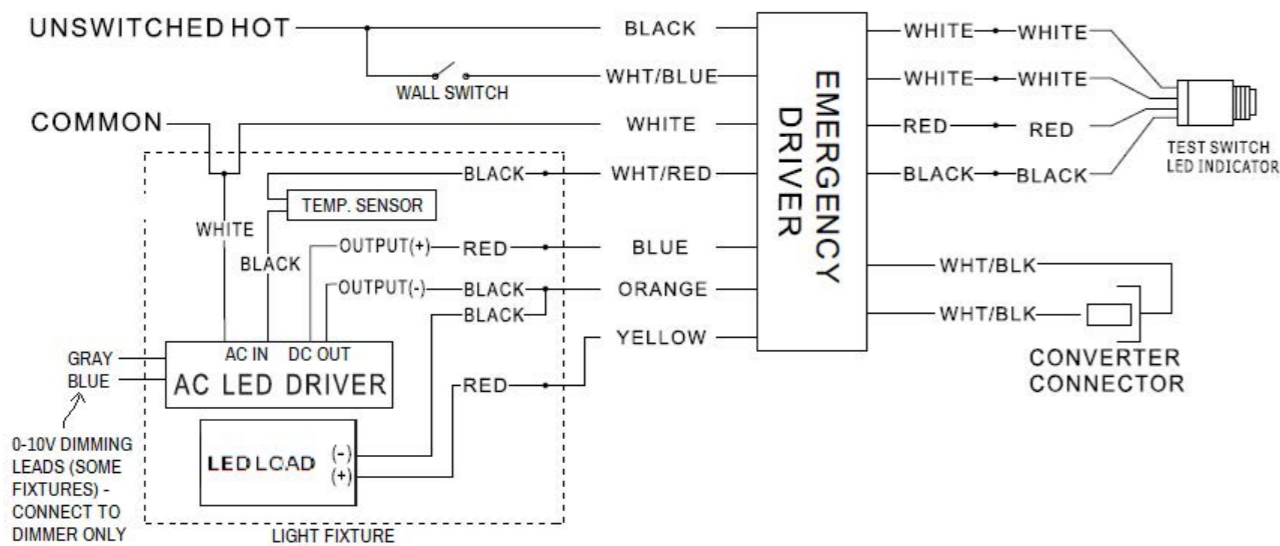

TYPICAL SCHEMATICS ONLY. MAY BE USED WITH OTHER DRIVERS. CONSULT THE FACTORY FOR OTHER WIRING DIAGRAMS.

BLOCK DIAGRAM OF TYPICAL QUANTALIGHT PL SERIES CYLINDER (STANDARD DRIVER SHOWN)

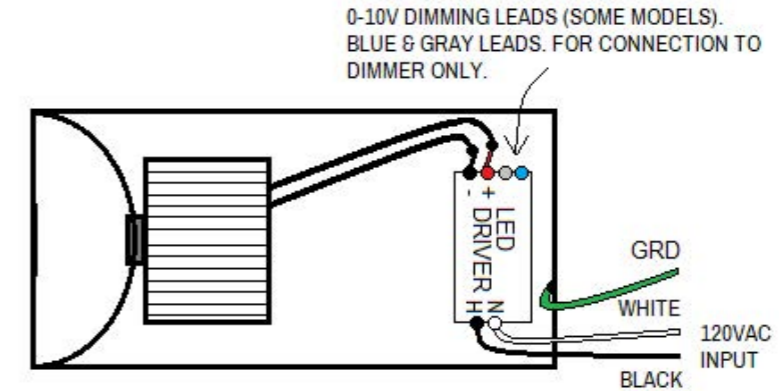

BLOCK DIAGRAM OF TYPICAL QUANTALIGHT RL SERIES DOWNLIGHTS (STANDARD DRIVER SHOWN)

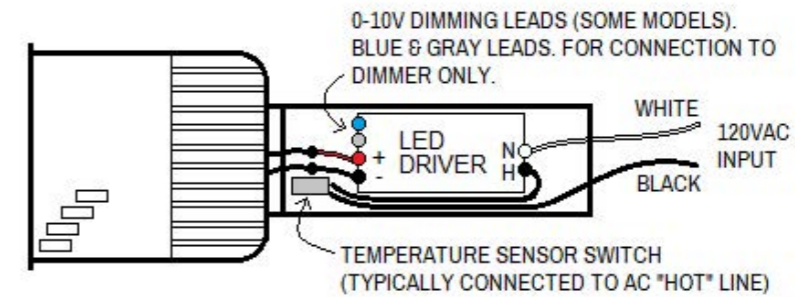

Operation

When AC power is applied, the charging indicator light is illuminated, indicating the batteries are being charged. When power fails, the emergency driver automatically switches to emergency power, operating the emergency LED load at reduced illumination. When AC power is restored, the emergency driver returns to the charging mode. This emergency driver will operate an LED lighting load supplies up to 25W constant power with output voltage between 20 VDC and 50 VDC in emergency mode for minimum of 90 minutes.

KEEP THESE INSTRUCTIONS FOR FUTURE REFERENCE. INSTALLER: GIVE THESE INSTRUCTIONS TO THE END USER OR FACILITY MANAGER.

Maintenance

Although no routine maintenance is required to keep the emergency driver functional, it should be checked periodically to ensure that it is working. The following schedule is recommended:

1. Visually inspect the charging indicator light monthly. It should be illuminated.
2. Test the emergency operation of the fixture at 30-day intervals for a minimum of 30 seconds. The LED lighting load should operate at reduced illumination.
3. Conduct a 90-minute discharge test once a year. The emergency LED load should operate at reduced illumination for a minimum of 90 minutes.
4. The life expectancy of the batteries is at least 4 years. Integral battery is not replaceable, replace entire unit when necessary.

Contains LiFePO4
Rechargeable Battery. Must
be recycled or disposed
properly.

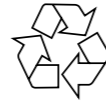

Remote Mounting Option

If the emergency driver unit is to power light fixtures installed in an unconditioned space (i.e. in an exterior soffit, hot roof, shed, or commercial sign) that will be exposed to direct sunlight and have little or no fresh air circulation, then the emergency driver should be cooled with a fan or installed remotely in a conditioned space within the building envelope. If not possible, consider installing a weather proof box nearby within a wall *that is shaded*.

Place the emergency driver(s) inside of the weather proof box (ensure the box is large enough to maintain air circulation within for cooling).

Use 18AWG as a minimum for the low-voltage LED leads up to 10ft, otherwise use 16AWG for the low-voltage leads for up to 20ft. Wires for the LED must be rated for the output of the driver (which can be up to 25W at 50VDC). Protect the wires within conduit. Test the circuit using the intended lengths prior to permanent mounting to ensure the LED lights correctly when on battery power mode.

There are many electrical boxes available online and from your electrical distributor, some for interior use only, and some for exterior use. Box must be grounded. For exteriors, a recessed, flush-mounted stainless steel box with a lock is recommended (see photo below).



Best Practices

To maximize the performance and lifespan of your LiFePO4 battery, avoid these common mistakes:

Ignoring temperature specifications: Operating the battery outside its recommended temperature range can lead to irreversible damage and reduced performance.

Inadequate thermal management: Failing to provide proper insulation or cooling can result in temperature-related issues, including reduced capacity and shortened lifespan.

Placing in sun or near heat sources: Keep the battery away from direct sunlight or heat sources to prevent overheating.

Placing in hot roof or box: Do not locate under a hot roof or in a small sealed box. Do not locate inside an exterior sign that is exposed to sunlight.

To maintain the optimal temperature for your LiFePO4 battery, consider the following tips:

Proper insulation: If installing inside a freezer, ensure that the battery is insulated. This helps maintain output current during operation. The best solution is to install remotely where it will be at room temperature.

Appropriate cooling: If installed in an unconditioned space (i.e. in an exterior soffit, shed, or commercial sign), employ active or passive cooling techniques, such as heat sinks, or fans to dissipate excess heat during high-temperature operation. Or install remotely in a conditioned space.

Environment control: Store and operate the battery in temperature-controlled environments whenever possible.